



SHURE MODEL 450 SERIES II PAGING AND DISPATCHING MICROPHONE

The Shure Model 450 Series II is a high output dynamic microphone designed for paging and dispatching applications. This extremely rugged microphone features an omnidirectional pickup pattern and a frequency response tailored for optimum speech intelligibility. It also includes an impedance selection switch and a locking press-to-talk switch. The press-to-talk switch can be converted to a monitor/transmit switch with the Shure RK199S Split-Bar Conversion Kit.

Features

- *Dual impedance*
- *Locking press-to-talk switch*
- *Rugged ARMO-DUR® base and case*
- *Adjustable height*
- *Optional monitor/transmit switch conversion kit*

PRESS-TO-TALK SWITCH OPERATION

To operate the control bar as a press-to-talk switch, simply hold it down and begin speaking. When you are finished speaking, release the control bar.

To lock the control bar in the “on” position, press it down and pull it forward. To unlock the control bar, push it back and release it.

IMPEDANCE SELECTION

To select high or low impedance, move the impedance selection switch, located under the microphone base, to either the HIGH or LO position. The switch is factory pre-set to LO.

Shure recommends the low impedance setting if long lengths of cable are used, or if severe hum is encountered. Use Shure A95 Line Matching Transformers to match a low impedance (300 Ω) microphone line to a high impedance amplifier input.

WIRING CONNECTIONS

Refer to Figure 1 and Table 1 below. For unbalanced operation, the GREEN wire is connected to the audio input, the WHITE wire is connected to the audio ground, and the SHIELD is connected to chassis ground. In some cases, audio ground and chassis ground will be the same.

For balanced operation, the GREEN wire is connected to the positive audio input, the WHITE wire is connected to the negative audio input, and the SHIELD is connected to chassis ground.

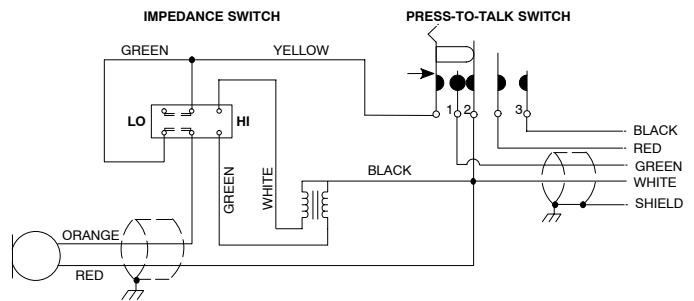

WIRING DIAGRAM

FIGURE 1

Table 1. Typical Cable-to-Connector Wiring

INPUT TYPE	WIRE COLOR	FUNCTION	XLR CONNECTOR	1/4 IN. PHONE JACK
UNBALANCED	GREEN	AUDIO	PIN 2	TIP
	WHITE	AUDIO GROUND	PIN 3	SLEEVE
	SHIELD	CHASSIS GROUND	PIN 1	SLEEVE
BALANCED	GREEN	AUDIO +	PIN 2	TIP
	WHITE	AUDIO -	PIN 3	RING
	SHIELD	CHASSIS GROUND	PIN 1	SLEEVE

NOTE: The RED and BLACK leads are not part of the audio circuit. These wires provide a contact closure when the press-to-talk switch is depressed. This closure may be used to control an external relay or a transmit/receive circuit.

CHANGING PTT CIRCUIT TO NORMALLY OPEN

Using microphones in parallel requires a normally open microphone circuit. To modify the press-to-talk switch so that it provides a normally open circuit, proceed as follows:

1. Remove the screws, washers, and bottom plate from the microphone.
2. Unsolder the black, red, and white leads from terminals 2 and 3 of the press-to-talk switch (see Figure 1). Make sure these leads are still soldered together. If necessary, resolder them and insulate the connection.
3. Replace the bottom plate and secure it with the screws and washers removed in Step 1.

TRANSMIT/MONITOR SWITCH CONVERSION KIT

When the optional split-bar Transmit/Monitor Switch Conversion Kit is installed, the Monitor bar must be depressed before the Transmit switch can be depressed, requiring the operator to verify that the channel is open before transmitting. The Monitor bar can be locked in the "on" position. The Transmit bar is momentary and cannot be locked.

NOTE: Transceiver wiring information must be obtained from the transceiver schematic and/or the manufacturer.

SPECIFICATIONS

Type

Dynamic

Frequency Response

200 to 5,000 Hz (see Figure 2)

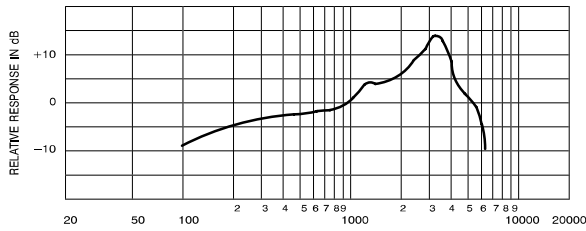

TYPICAL FREQUENCY RESPONSE
FIGURE 2

Polar Pattern

Omnidirectional

Impedance (at 1,000 Hz)

High Impedance: 30,000 Ω

Low Impedance: 225 Ω

Recommended Load Impedance

High Impedance: 100,000 Ω

Low Impedance: 1,000 Ω

Output Level (at 1,000 Hz, Open Circuit Voltage)

High Impedance
-35.0 dBV/Pa*
(17.8 mV)

Low Impedance
-57.0 dBV/Pa*
(1.4 mV)

*1 Pa = 94 dB SPL

Switches

Locking Press-to-Talk Switch: Activates microphone circuit and an external relay or control circuit. The microphone circuit is normally shorted.

Impedance Selection Switch: Double-pole, double-throw slide switch located in the base of the microphone.

Cable

2.1 m (7 ft.) four-conductor, two conductors shielded, non-detachable

Case

Two-tone gray ARMO-DUR®

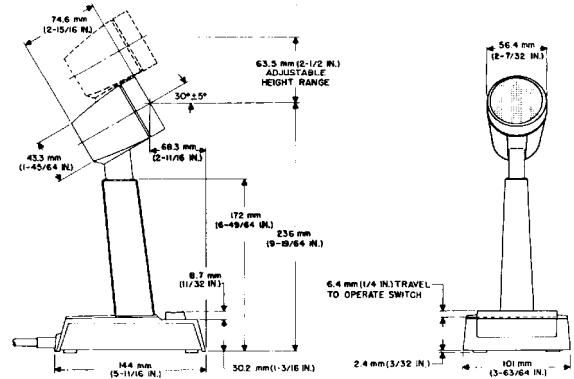

OVERALL DIMENSIONS
FIGURE 3

Net Weight

737 grams (1 lb., 10 oz.)

Shipping Weight

1020 grams (2 lb., 4 oz.)

Certification

Conforms to European Union directives, eligible to bear CE marking; meets European Union EMC Immunity Requirements (EN 50082-1, 1992).

REPLACEMENT PARTS

- Cartridge R96
- Cable C31C
- On/Off Switch RK141S

OPTIONAL ACCESSORIES

- Transmit/Monitor Split-Bar Switch Kit RK199S



SHURE Incorporated Web Address: <http://www.shure.com>
 5800 W. Touhy Avenue, Niles, IL 60714-4608, U.S.A.
 Phone: 800-257-4873 Fax: 847-600-1212
 In Europe, Phone: 49-7131-72140 Fax: 49-7131-721414
 In Asia, Phone: 852-2893-4290 Fax: 852-2893-4055
 Elsewhere, Phone: 847-600-2000 Fax: 847-600-6446